



Flextrusion Tooling

Patent pending tooling system provides the plastic extrusion industry a new level of process control that maximizes quality and minimizes scrap.



www.extrudeNow.com

Double Compression

The Double Compression design conditions the material and removes defects caused by die spiders and lack of compression. An internal temperature sensor gives unprecedented feedback about the state of the extrusion process, allowing the operator to run at peak efficiency.

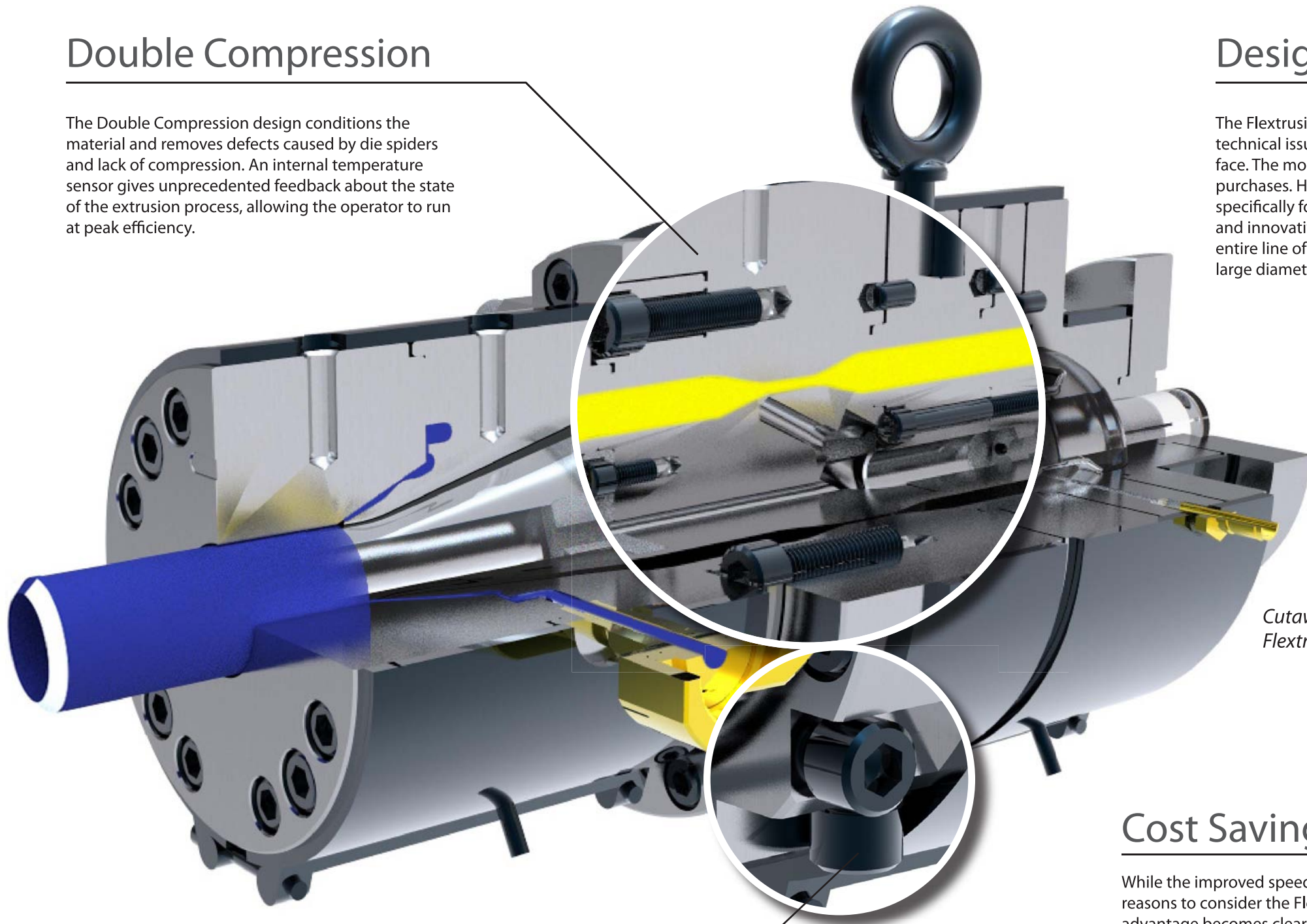

Designed for Growth

The Flextrusion System solves the toughest technical issues the extrusion industry has to face. The modular design leverages tooling purchases. HG Engineering can develop dies specifically for your needs. The adjustability and innovative design extend to the entire line of solutions for co-extrusion, large diameters and custom profiles.

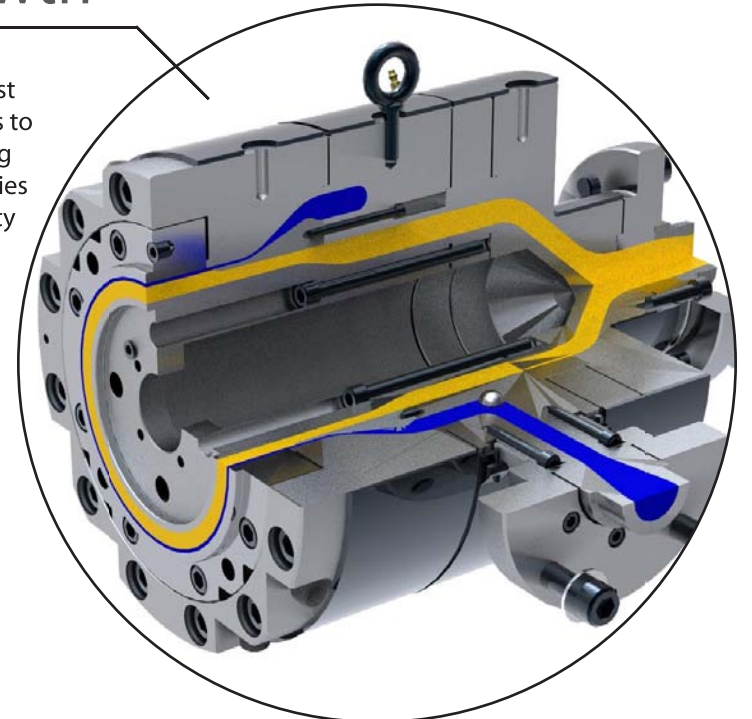

Cutaway view of Flextrusion die head

Precision Wall Thickness Adjustment

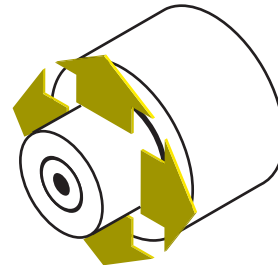

No other tooling gives you the kind of robust and repeatable control over the wall thickness of the final product. Precision XY adjustment allows you to compensate for variabilities within the plastic flow.

Cost Savings

While the improved speed and quality are enough reasons to consider the Flextrusion System, the real advantage becomes clear when you consider the cost over one-year ownership and operation. By reducing the change-over times dramatically, providing faster process optimization and reducing product variability, this system provides significant savings. This spreadsheet illustrates the cost savings a typical company will realize (when not capable of recycling scrap).

Example of Cost Savings for PEX Production

	Traditional	Flextrusion
Product Output Rate (lbs/hr)	500	500
Cost of Materials (\$/lb.)	\$0.40	\$0.40
Operating Hrs / Yr	7,426	7,426
Total Cost of Changeover Scrap / Yr	\$42,752	\$5,344
Total Cost of Changeover Time / Yr	\$22,880	\$2,860
Total Cost of Production Scrap / Yr	\$178,020	\$30,418
Total Cost of Lost Production Time / Yr	\$47,636	\$8,140
Annual Operating Costs	\$291,288	\$46,762

Single Year Potential Cost Savings using the Flextrusion System \$244,526

A more detailed and interactive spreadsheet is available from HG Engineering that allows you to calculate your estimated cost savings on your specific operating parameters.

Please contact HG Engineering to obtain a detailed copy of this savings calculator.

Flextrusion Calibrator

HG Engineering did not stop with head and die design; it continued to the development of the world's first triple helix calibrator. This Flextrusion Calibrator uses a patent pending adjustable pipe sizing sleeve to provide precise adjustability during start-up and operation.

In addition to this in-process adjustability, the new design rethinks the way extrudate is cooled. Due to thermal efficiency production rates are increased.

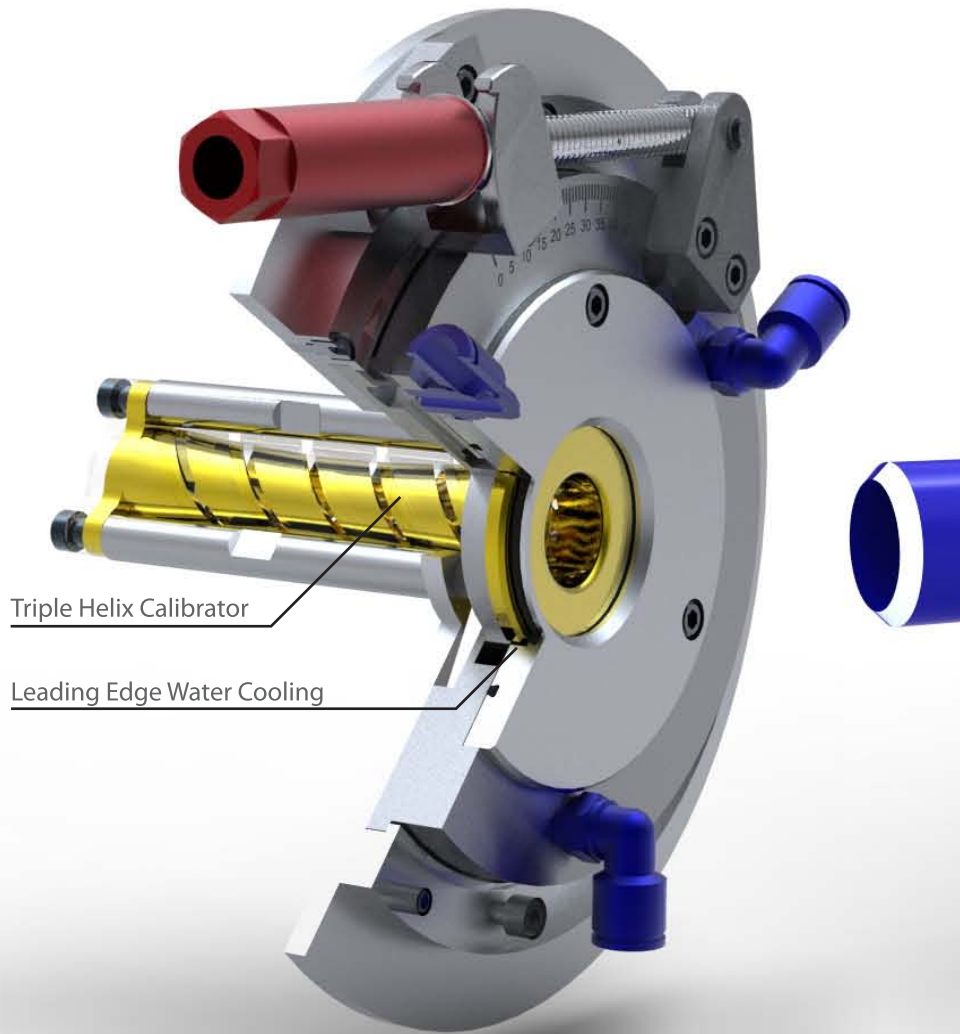

HG Engineering

HG Engineering has more than 25 years experience in design and development of extrusion technology. The company collaborates with a wide range of extrusion companies and equipment manufacturers across the globe. Therefore, HG Engineering has a fundamental understanding of the bottlenecks and challenges the extrusion industry faces. The company develops solutions to overcome these challenges prudently and increase product quality.



HG Engineering, LLC

719 N. Main - P.O. Box 706
McPherson, KS 67460

(620) 241- 4401 or (620) 245-4702

E-mail: hansg@att.net

www.extrudeNow.com